

DEVANTI

USER MANUAL

ICE MAKER

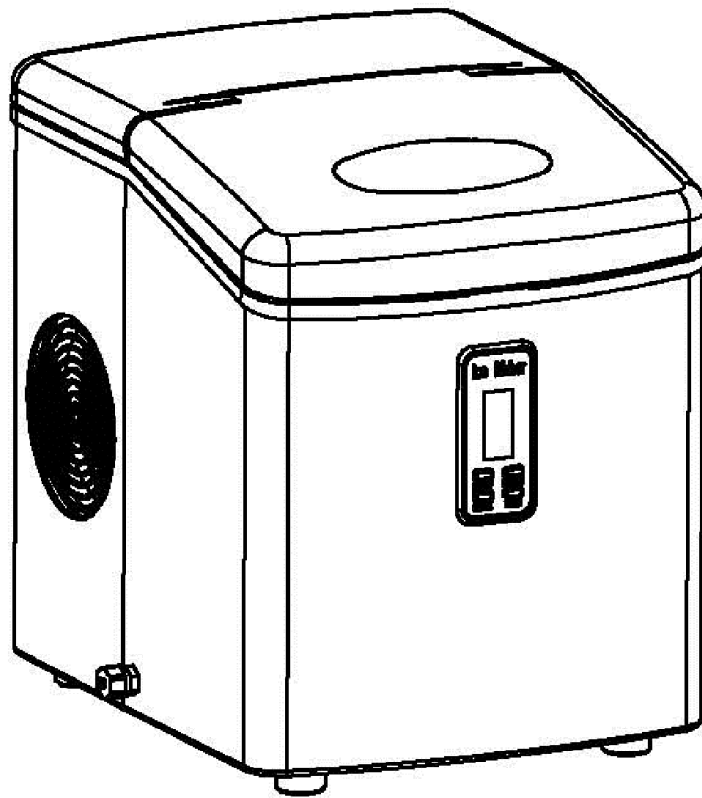

Model: IM-ZB12S-SS
IM-ZB12S-BK

TABLE OF CONTENTS

IMPORTANT SAFETY INSTRUCTIONS	2
PREPARING YOUR ICE MAKER FOR USE	
IMPORTANT SAFETY TIPS.....	3
GETTING TO KNOW YOUR UNIT	4
OPERATING PROCEDURES & MAINTENANCE	
UNPACKING YOUR ICE MAKER.....	5
CONNECTING YOUR ICE MAKER.....	5
CLEANING AND MAINTAINING YOUR ICE MAKER.....	5
USING YOUR ICE MAKER	
START TO MAKE THE ICE-CUBE.....	6
TIMER SETTING.....	6
CLOCK DISPLAY & THE CORRECT TIME.....	7
CLEANING REMINDING.....	7
TROUBLESHOOTING.....	8
TECHNICAL PARAMETERS & CIRCUIT DIAGRAM	
TECHNICAL SPECIFICATION.....	8
CIRCUIT DIAGRAM.....	9
WARRANTY INFORMATION	9

IMPORTANT SAFETY INSTRUCTIONS

Your safety and the safety of others are very important.

We have provided many important safety messages manual and your appliance.
Always read and obey all safety messages.

This is the safety alert symbol:



All safety messages will follow the safety alert symbol and the word “DANGER” or “WARNING”.



DANGER



WARNING

These words mean:

You can be killed or seriously injured if you don't immediate follow instructions.

All safety messages will tell you what the potential hazard is, tell you how to reduce the chance of injury, and tell you what can happen if the instructions are not followed.

PREPARING YOUR ICE MAKER FOR USE

IMPORTANT SAFETY TIPS

When using electrical appliances, basic safety precautions should be followed to reduce the risk of fire, electric shock, and injury to persons or property. Read all instructions before using any appliance.

- This appliance can be used by children aged from 8 years and above and persons with reduced physical, sensory or mental capabilities or lack of experience and knowledge if they have been given supervision or instruction concerning use of the appliance in a safe way and understand the hazards involved. Children shall not play with the appliance. Cleaning and user maintenance shall not be made by children without supervision.
- Do not operate this, or any other appliance with a damaged cord.
If the supply cord is damaged, it must be replaced by the manufacturer or its service agent or a similarly qualified person in order to avoid a hazard.
This ice-maker must be positioned so that the plug is accessible .
Connect to properly polarized outlets only. No other appliance should be plugged into the same outlet. Be sure that the plug is fully inserted into the receptacle.
- Do not run the power cord over carpeting or other heat insulators. Do not cover the cord. Keep cord away from traffic areas, and do not submerge in water.
- We do not recommend the use of an extension cord, as it may overheat and become a risk of fire. If you must use an extension cord, use No.0.75mm² minimum size and rated no less than 16A/250V~ with a plug.
- Unplug the ice maker before cleaning or making any repairs or servicing.
- Exercise caution and use reasonable supervision when appliance is used near children.
- Do not use your ice-maker outdoors. Place the ice-maker away from direct sunlight and make sure that there is at least 4 inches of space between the back of your unit and wall. Keep a minimum distance of 4 inches on each side of your unit free.
- Do not use other liquid to make the ice-cube other than water.
- Do not clean your ice maker with flammable fluids. The fumes can create a fire hazard or explosion.
- Do not tip over.
- If the ice maker is brought in from outside in wintertime, give it a few hours to warm up to room temperature before plugging it in.
- This appliance is not intended for use by persons (including children) with reduced physical, sensory or mental capabilities, or lack of experience and knowledge, unless they have been

given supervision or instruction concerning use of the appliance by-a person responsible for their safety.

- Young children should be supervised to ensure that they do not play with the appliance.
- Please according to local regulations regarding disposal of the appliance for its flammable blowing gas. Before you scrap the appliance, please take off the doors to prevent children trapped.
- Do not store explosive substances such as aerosol cans with a flammable propellant in this appliance.
- This appliance is intended to be used in household and similar applications such as
 - staff kitchen areas in shops, offices and other working environments;
 - farm houses and by clients in hotels, motels and other residential type environments;
 - bed and breakfast type environments;
 - catering and similar non-retail applications.



- **Warning: Risk of fire/flammable materials used.** Please according to local regulations regarding disposal of the appliance for its flammable blowing gas.
- **WARNING:** Keep ventilation openings, in the appliance enclosure or in the built-in structure, clear of obstruction.
- **WANING:** Do not damage the refrigerant circuit.
- **WARNING:** Do not use mechanical devices or other means to accelerate the defrosting process or ice harvesting process, other than those recommended by the manufacturer.
- **WARNING:** Do not use other type of electrical appliances inside the ice-maker.
- This appliance must be earthed.

IMPORTANT:

The wires in this mains lead are colored in accordance with the following code:

Green and yellow:	Grounding
Blue:	Neutral
Brown:	Live

To avoid a hazard due to instability of the appliance, it must be placed at a even or flat surface.

GETTING TO KNOW YOUR UNIT

1. Cover: With a transparent window to allow interior visibility.
2. Ice scoop.
3. Ice shovel.
4. Control Panel: Easy to use, visible functions and LCD display setting.
 - A. LCD display window.
 - 1: Current Clock Time
 - 2: No water display, When flashing, means no water in the unit, need to pour water in.
 - 3: Ice-full display, when it display, means the ice basket is full of ice-cube.
 4. ON/OFF display, if the unit has been turned off, this symbol will flash; And if the unit is turned on, this symbol will always display.
 5. Clean symbol: when this symbol flashes, means the unit need to be cleaned.
 6. Ice-cube size displaying: Small, Medium, and Large.
 7. Timer delay time display.
 - B. ON/OFF button: To start or stop the unit.
 - C. SELECT button: To select your desired size of the ice-cube:

small, medium, large, three size of the ice-cube can be selected.

Or to change the time digit during the clock or timer setting program.
 - D. CLOCK button: To set the displayed time to the correct current time.
 - E. TIMER button: To set or cancel the timer program to let the unit start to run at your desired time or stop the unit at your desired because of forgetting.
5. Water drain cap: For draining water from water reservoir.
6. Air Outlet
7. Ice basket

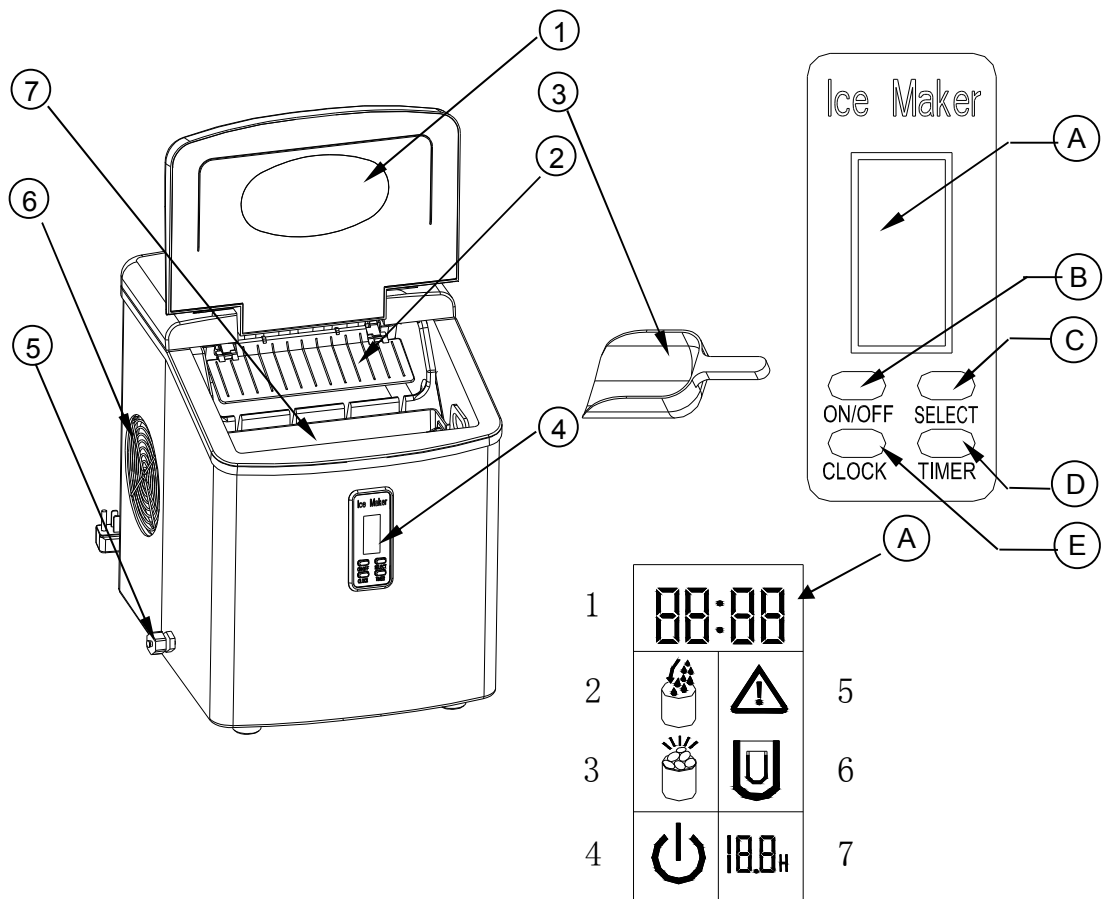

OPERATING PROCEDURES & MAINTENANCE

UNPACKING YOUR ICE MAKER

1. Remove the exterior and interior packaging. Check that ice basket and ice scoop is included. If any parts are missing, please contact our customer service.
2. Clean the interior with lukewarm water and a soft cloth. Take out the ice basket and clean it
3. Find a location for your ice maker that is protected from direct sunlight and other sources of heat (i.e.: stove, furnace, radiator). Place the ice maker on a level surface. Make sure that there is at least 4 inches of space between the back and sides of your ice maker and the wall.
4. Allow one hour for the refrigerant fluid to settle before plugging ice maker in.
5. The appliance must be positioned so that the plug is accessible.

WARNING: fill with potable water only.

CONNECTING YOUR ICE MAKER



DANGER

*** Improper use of the grounded plug can result in the risk of electrical shock. If the power cord is damaged please call our customer service.**

1. This unit should be properly grounded for your safety. The power cord of this appliance is equipped with a grounding plug which mates with standard grounding wall outlets to minimize the possibility of electric shock.
2. Plug your appliance into an exclusive, properly installed, grounding wall outlet. Do not under any circumstances, damage the grounding means of the plug under any circumstances. Any questions concerning power and/or grounding should be directed toward a certified electrician.
3. This appliance requires a standard 220-240Volt, 50Hz electrical outlet with good grounding means.

CLEANING AND MAINTAINING YOUR ICE MAKER

Before using your ice maker, it is strongly recommended to clean it thoroughly.

1. Take out the ice basket.
2. Clean the interior with diluted detergent, warm water and a soft cloth.
3. Then use the water to rinse the inside parts, and drain out the water by unplugging the drain cap on the side.
4. The outside of the ice maker should be cleaned regularly with a mild detergent solution and warm water.
5. Dry the interior and exterior with a soft cloth.
6. When the machine is not in use for a long time, open water drained cap to drain water completely from water reservoir.

Note: Blowing gas inside the unit is flammable, disposal of these material shall be in accordance with national regulations.

USING YOUR ICE MAKER

START TO MAKE THE ICE-CUBE

1. Open the cover, remove the ice basket and pour water into water reservoir. Keep water level below the level mark.
2. Press “ON/OFF” button on the control panel to turn on the unit to begin the ice making cycle.
3. Select the size of the ice cube by pressing the “Select” button. Three sizes: SMALL, MEDIUM or LARGE can be selected:

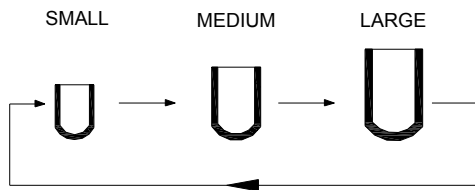

If the room temperature is lower than 60 °F , it is recommended to select the small or medium ice sign button in order to avoid ice sticking together.

4. The ice making cycle lasts 6 to 13 minutes, depending on the size of the ice cube selection and the ambient temperature. In the extreme hot room temperature, ice-making time maybe vary a lot.
5. While the icemaker is on, verify water level periodically. If water pump can't inject water, the

ice maker will stop automatically, and the “” symbol will flash in LCD display window. Fill water up to the level mark and press “ON/OFF” button two times again to turn on the unit again. Allow the refrigerant liquid inside the compressor at least 3 minutes to settle before restarting.

6. The ice maker automatically stops working when the ice basket is full and the “” symbol will display in the LCD display widow.
7. Change water in the water reservoir every 24 hours to ensure a reasonable hygiene level. If unit isn't in use, drain all water left in the tank.

TIMER SETTING

Timer Delay Time Range: 0.5-19.5 hours.

Default Delay Time: 3 hours.

When the unit is running, you can set the unit with OFF-TIMER to let the unit stop running after your set delay time.

And when the unit is stopped, you can set the unit with ON-TIMER to let the unit start to run automatically after your set delay time, then when you go back home or have a dinner, you can enjoy the happy life that this ice-maker give to you.

How to set the timer

Press the TIMER button first, the default “3.0H” delay time will flash in LCD display window,

then press the SELECT button to select your desired delay time. Each press SELECT button one time, the flashing delay time will increase 0.5 hour, and if you always press the SELECT button for more than 3 seconds, the delay time will change very quickly. Then after 5 seconds flashing, the delay time digit will change from flashing to always displaying, means the timer program has been set.

How to cancel the timer

When the unit has been set with the timer or during the timer setting process, press the TIMER button, then the delay time digit will disappear, mean the timer set has been cancelled.

CLOCK DISPLAY & THE CORRECT TIME

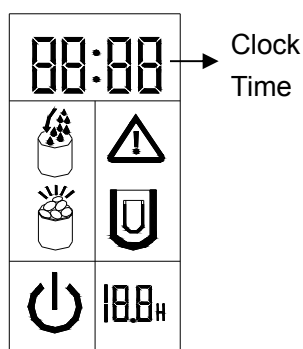

This unit is supplied with CLOCK displaying function.



If the displayed time is not correct, you can adjust it to the correct digit through the CLOCK and SELECT button.

First press the CLOCK button once, the digit meaning hour will start to flash first, then you can press SELECT button to change it, each press will increase 1 hour. Press the CLOCK button again, the digit meaning minute then will start to flash, and also press the SELECT to change it. Then press the CLOCK the third time to confirm it, and now it display the new correct clock. And during adjusting process, after 5 seconds flashing, the digit will automaticall change to always displaying, also means the new clock has been set.

CLEANING REMINDING

When the symbol  flashes, means the unit need to be cleaned. And if you have cleaned the unit, always press the TIMER button for more than 5 seconds, this symbol will disappear from the LCD display window. And the cleaning timer will reset to Zero and reaccount again.

TROUBLESHOOTING

PROBLEM	POSSIBLE CAUSE	SOLUTION
Symbol “  ” flashes.	Lack of Water.	Stop the ice maker, fill water, and press “ON/OFF” button again to restart the unit.
Symbol“  ” display in LCD display window.	There is too much ice.	Remove ice from ice basket.
Ice cubes stick together.	The ice cycle is too long.	Stop the ice maker, and restart it when the ice blocks melt. Select the small size ice cube selection.
	Water temperature in inner tank is too low.	Change the water in the inner Tank. Temperature of water is better set between 8–32°C
Ice making cycle is normal but no ice is made.	Ambient temperature or water temperature in inner tank is too high.	Please run the ice maker below 32°C and pour colder water into tank.
	Refrigerant in cooling system leaks.	Verify by a qualified technician.
	Pipe in the cooling system is blocked.	Verify by a qualified technician.

TECHNICAL PARAMETERS & CIRCUIT DIAGRAM

TECHNICAL PARAMETERS

Model	IM-ZB12S-SS	IM-ZB12S-BK
Protection Type	I	I
Climate Type	SN/N/ST/T	SN/N/ST
Power	220-240V/50Hz	220-240V/50Hz
Ice Making Current	0.7A	0.7A
Ice Harvest Current	1.0A	1.0A
Refrigerant	R600a/29g	R600a/29g
Net Weight	10.5kg	10.5kg
Vesicant	C ₅ H ₁₀	C ₅ H ₁₀
Enclosure	stainless steel	stainless steel
Dimension (WxDxH)	297x367x378mm	297x367x378mm

CIRCUIT DIAGRAM

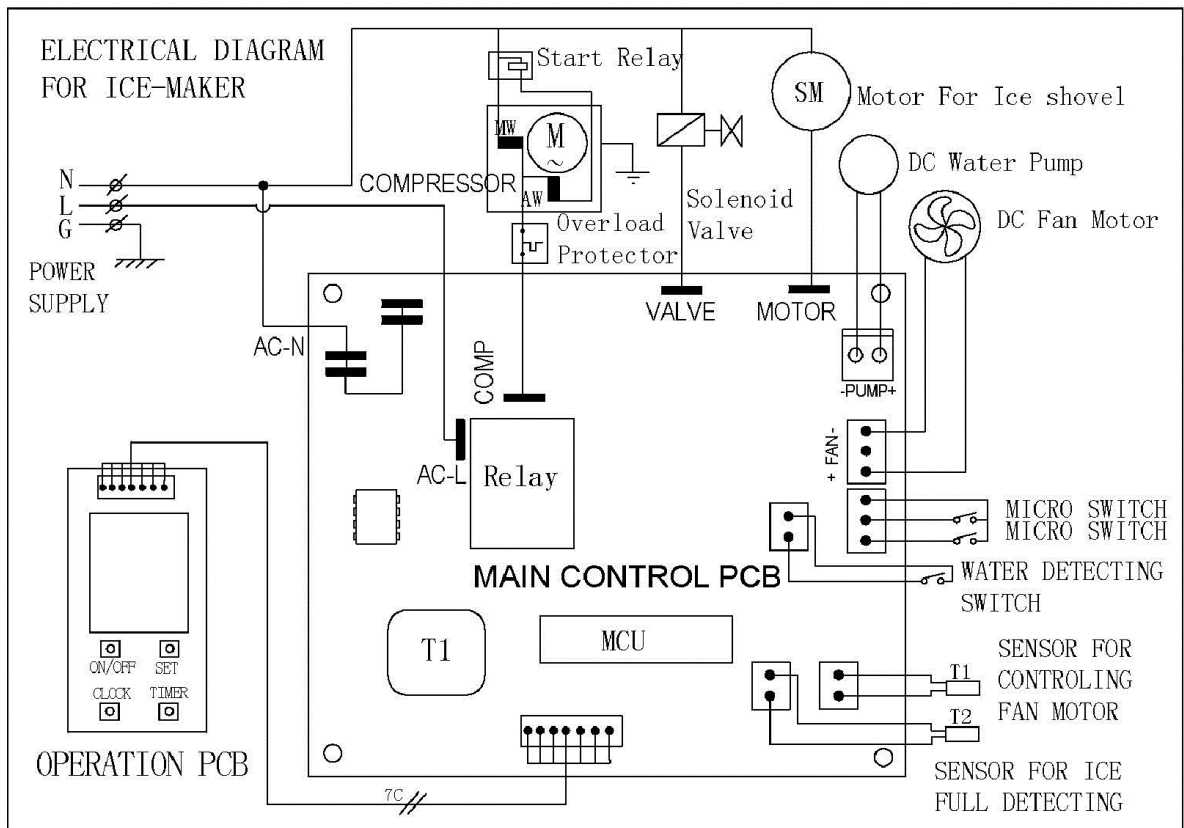

Warranty Information

- **WARNING:** Keep ventilation openings, in the appliance enclosure or in the built-in structure, clear of obstruction.
- **WARNING:** Do not damage the refrigerant circuit.

The manufacturer provides warranty in accordance with the legislation of the customer's own country of residence, with a minimum of 1 year (Germany: 2 years), starting from the date on which the appliance is sold to the end user.

The warranty only covers defects in material or workmanship.

The repairs under warranty may only be carried out by an authorized service centre. When making a claim under the warranty, the original bill of purchase (with purchase date) must be submitted.

The warranty will not apply in cases of:

- Normal wear and tear
- Incorrect use, e.g. overloading of the appliance, use of non-approved accessories
- Use of force, damage caused by external influences
- Damage caused by non-observance of the user manual, e.g. connection to an unsuitable

mains supply or non-compliance with the installation instructions

- Partially or completely dismantled appliances

Correct Disposal of this product	
	<p>This marking indicates that this product should not be disposed with other household wastes throughout the EU. To prevent possible harm to the environment or human health from uncontrolled waste disposal, recycle it responsibly to promote the sustainable reuse of material resources. To return your used device, please use the return and collection systems or contact the retailer where the product was purchased. They can take this product for environmental safe recycling.</p>